

Cold welding

Cold welding (or “contact-welding”, “adhesion”, “stiction”) is a solid-state welding process in which joining takes place without fusion/heating at the interface of the two parts. Coldwelding is likely to occur in metal-metal contacts in vacuum. This can lead to failure of space mechanism, which are typically stored compact while launch and are unfolded for their mission in orbit.

AAC’s test-facilities enable the measurement of the adhesion force between two materials in cyclic closed contacts which are subjected to fretting. This means that pin and disc are oscillated in their contact plane with small amplitudes (50 µm). "Cyclic contact" means that the contact between the pin and the disc is closed and opened for several (thousand) cycles.

Post-test analysis may cover measurement of wear by profilometry, state of coating, investigation of surface structure or material transfer by SEM/EDX.

Measurement of

- Adhesion force
- Friction force
- Load force
- Lateral amplitude
- Environmental Data

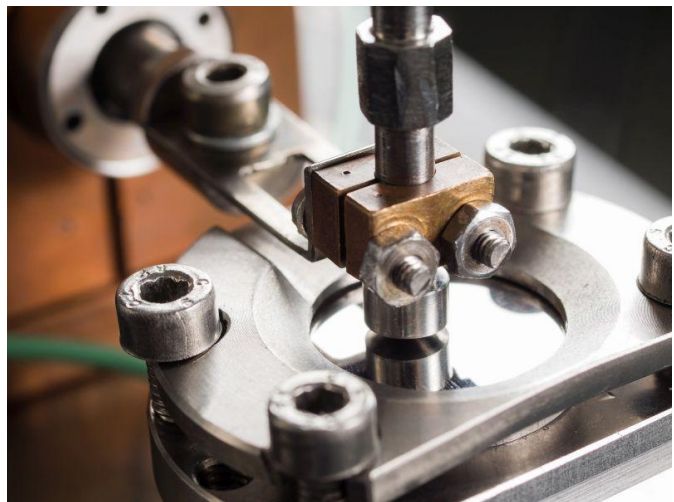

Figure 1: Cold welding facility (Pin-on-Disc system)

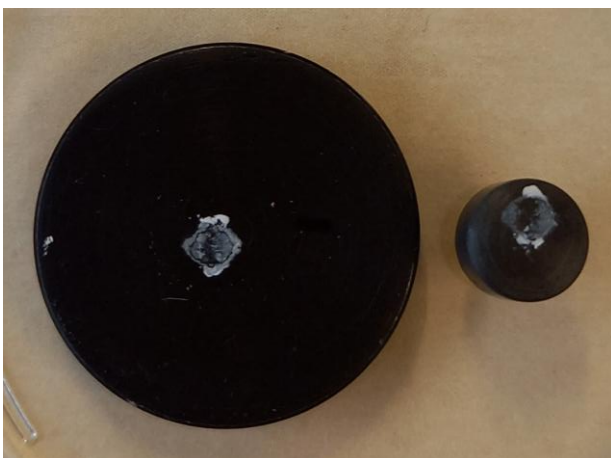

Figure 2: Typical damage of coatings under fretting treatment

Different options are available (on demand)

- Testing from air to high vacuum – simulation of launch conditions
- Testing in controlled gas environment – e.g. simulating Martian atmosphere (6 mbar in CO₂)
- Testing according to STM279, long term vacuum

Three test-facilities are available at AAC, whereby the lateral motion can be

- forced motion (pin is directly actuated) or
- “passive” motion (pin is loaded onto a shaker and not actively activated)

For ESA member states a cost-free database for the most common material combinations is available (registration needed).

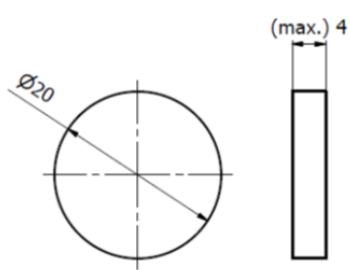
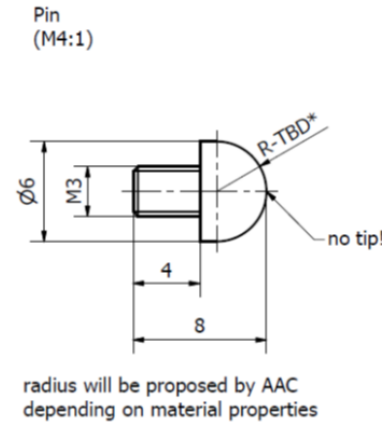
Specifications	
Samples (Dimensions in mm)	<div style="display: flex; justify-content: space-around; align-items: flex-start;"> <div style="text-align: center;"> <p>Disc (M2:1)</p>  </div> <div style="text-align: center;"> <p>Pin (M4:1)</p>  </div> </div>
Test (Output)	online measurement of <ul style="list-style-type: none"> • Adhesion force • Environmental Data
Loads	1 - 10 N – Hertzian contact pressure is adjusted with Load and Radius of Pin
Speed / Motion	Fretting movement: 10Hz to 300Hz (typical 210Hz) Fretting amplitude: 10µm to 100µm (typical 50µm)
Vacuum / Environments	Vacuum selectable down to 10 ⁻⁶ mbar Air with controlled humidity Gases with controllable pressure (e.g. CO ₂ at 6mbar)
Temperatures	Room-temperature
Accuracy	Adhesion force: ±30mN
Database for ESA members	http://coldweld.aac-research.at/