

Cryo Vacuum Tribometer

The "Cryo-tribometer" enables to derive friction and wear from cryogenic temperatures up to RT. It works in gHe (gaseous Helium) or vacuum environment.

The "Cryo-tribometer" is an adaption to the existing He-cryostat ("shroud"). It consists of a tube-like vacuum-chamber with a power train on tip of it. This "tube" will be mounted in a shroud.

This shroud (cryostat) is capable of cooling with liquid nitrogen or helium. The test-pair (containing "upper" and "lower" disc and three pins) are mounted inside a vacuum-tube so the wear contact is under vacuum (or gHe).

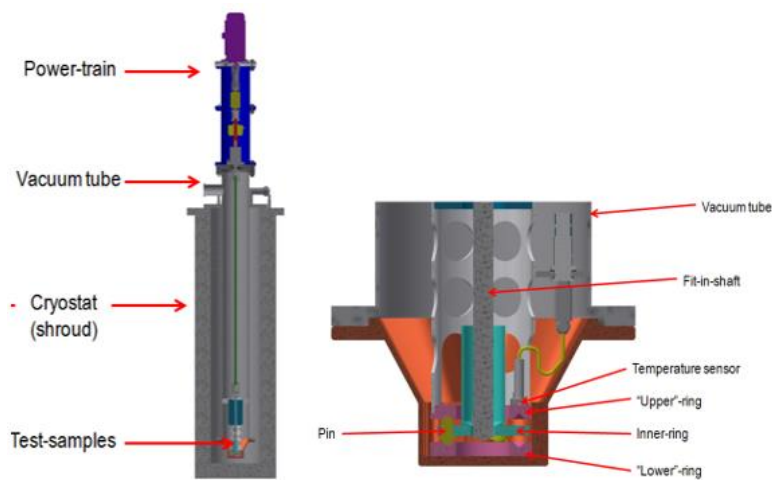

The power train consists of

- Servomotor
- Torque-sensor (strain gauge based)
- Angular sensor
- vacuum rotary feedthrough (for shaft)
- couplings for compensation of axial displacement



Lower Ring and 3 Pins

Cryo-Tribometer in shroud and section view

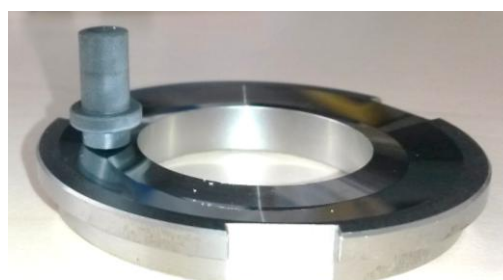

Specifications	
Samples	3-Pin-on-Ring <ul style="list-style-type: none"> • Pins DM 4 – 7 mm with spherical tips on both ends • Rings OD ~ 60mm with V-grooves for self-alignment (See Annex for drawings)
Test (Output)	online measurement of <ul style="list-style-type: none"> • Friction force / coefficient (Torque) • Temperature (on-line) Offline: Wear (geometric or mass loss)
Loads	1 – 20N (per pin), 100 to 2000 MPa
Motion Speed	Unidirectional or oscillating 0,01 to 0,2 m/s (< 100 RPM)
Vacuum / Environments	gHe down to high vacuum (10^{-5} mbar)
Temperatures	from RT down to 4K
Accuracy	Torque $\pm 0,01$ Nm (up to 5 Nm) Sample temperature ± 10 °C

Annex – Specimens (examples):

